

# Daniel John Povinelli

## *Behind the ape's appearance: Escaping anthropocentrism in the study of other minds*

**L**ook at Megan. Not just at her distinctively chimpanzee features – her accentuated brow ridge, her prognathic face, her coarse, black hair – but at the totality of her being; her darting eyes, her slow, studied movements, the gestures she makes as her companion, Jadine, passes nearby. Can there be any doubt that behind certain obvious differences in her appearance, resides a mind nearly identical to our own? Indeed, is it even possible to spend an afternoon with her and *not* come to this conclusion – not implant a human mind inside her chimpanzee skull? Upon reflection, you will probably acknowledge that her mind is *not identical* to ours. “But surely it’s not qualitatively different, either,” you will still insist. “I mean, it’s obvious from watching her that we share the same *kind* of mind.”

So, how can I devote the remainder of this essay to questioning the human-like quality of Megan’s mind? Faced with the overwhelming similarity in the spontaneous, everyday behavior

---

Daniel J. Povinelli is a Professor of Cognitive Science at the University of Louisiana at Lafayette, and is Director of the Cognitive Evolution Group and the Center for Child Studies. He is a James S. McDonnell Centennial Fellow, former recipient of a National Science Foundation Presidential Young Investigator Award, and recipient of the American Psychological Association’s Distinguished Scientific Award for an Early Career Contribution to Psychology. He is the author of numerous journal articles and book chapters and of *Folk physics for apes: The chimpanzee’s theory of how the world works* (Oxford University Press, 2000).

of humans and chimpanzees, how can someone like me – someone who has dedicated his life to studying these remarkable animals – entertain the possibility that their mental lives are, in profound respects, radically different from our own? How can I challenge the received wisdom of Darwin – confirmed by my own initial impressions – that their mental lives are best compared to that of human children?

Actually, it’s easy: I have learned to have more respect for them than that. I have slowly come to see that we distort their true nature by conceiving of their minds as smaller, duller, less-talkative versions of our own. Casting aside these insidious assumptions has been difficult, but it has allowed me to see more clearly that the human mind is not the gold-standard against which other minds must be judged. It also raises the possibility of considering the existing scientific evidence with a more sober eye, one which is less contaminated by our deeply anthropocentric intuitions about the nature of other minds.

**T**he best available estimates suggest that humans and chimpanzees originated from a common ancestor about 5 or 6 million years ago.<sup>1</sup> This is reflected in estimates of our genetic similarity: we share, on average, about 98.6% of our total nucleotide sequence in common. This statistic seems impressive. After all, such biological affinity would appear to be the final nail in the coffin of the notion that there could be any radical mental differences between them and us: if chimpanzees and humans share 98.6% of their genetic material, then doesn’t it follow that their ought to be an extraordinarily high degree of mental similarity as well? This idea has been paraded so frequently through the introductory paragraphs of both scholarly journal articles and the popular press alike, that it has come to constitute an anthem of sorts; a melody, which if not sung, raises doubts as to one’s allegiance to the cause of defending the chimpanzee’s dignity.

But what does this 98.6% statistic really mean? It should be of immediate interest that it is almost invariably misreported. We do not share 98.6% *of our genes* in common with

---

<sup>1</sup> Chen et al. “Genomic divergence between human and chimpanzee estimated from large-scale alignments of genomic sequences” *Journal of Heredity* 92 (2001): 481-489.

chimpanzees (as is so often reported); we share 98.6% of our nucleotide sequence. A single nucleotide difference in a string of 400 may code for a different allele. Furthermore, as the geneticist Jon Marks has pointed out in lucid detail, even accurately reported, the 98.6% statistic has so little grounding in the average mind that confronts it, that it is essentially meaningless.<sup>2</sup> For example, we might share 50% of our nucleotide sequences in common with bananas and broccoli. But what on earth does it mean to say that we are 50% the same as a vegetable? I don't know about you, but I doubt my mind is 50% identical to that of the garden pea. And so what would it mean, exactly, if we discovered that our minds were 75% chimpanzee?

No, such coarse genetic comparisons will hardly suffice to help us understand the complex similarities and differences that exist between the mental lives of humans and chimpanzees. However, in a climate in which chimpanzees have been radically anthropomorphized by certain highly visible experts,<sup>3</sup> such statistics are heralded as establishing once and for all that chimpanzees are, at the very least, mentally equivalent to two- or three-year-old human children, and should therefore be granted human rights.<sup>4</sup>

Still, a few obvious biological facts may be worth noting. To begin, it was the human lineage, not the chimpanzee one, that underwent radical changes after our respective lineages began to diverge from their common ancestor. Since this split, humans have re-sculpted their bodies from head to toe: quite literally, in fact. As our lineage became bipedal, the pelvis, the knee, and the foot, were all drastically re-shaped, with modifications in the hand (including new muscles) soon following. To top it all off, we ultimately tripled the size of our brain, probably focusing disproportionately on the seat of higher cognitive function: the prefrontal cortex. Oh yes, and at some point during all of this (no one

knows exactly when), natural language – perhaps the most noticeable of our adaptations – emerged as well.

In contrast, chimpanzees have probably changed relatively little from the common ancestor they shared with us about 5 million years ago. Indeed, of all of the members of the great ape/human group who shared a common ancestor about 15 million years ago, none have diverged as much as humans. A simple thought experiment may help to put this into perspective: line up all of the species in question: gorillas, orangutans, chimpanzees, bonobos, and humans. One of them immediately stands out. Guess which one?

In fact, the more we compare humans and chimpanzees, the more that the differences are becoming apparent. Even geneticists are starting to catch up with the reality of these differences. New research has shown that rough measures of the similarity in the nucleotide sequences obscures the fact that the same genes may have dramatically different activity levels in the two species. So even where humans and chimpanzees share genes in common, it turns out that there are what can only be described as major differences in gene *expression* – that is, whether, when, and for how long genes are actually working to produce the proteins for which they code.<sup>5</sup> This is the *real* stuff of genetic comparisons, and it casts our crude genetic similarity to the garden pea in a wholly different light.

Of course, what makes these differences in gene expression significant is they ultimately manifest themselves as differences in the bodies – including the brains – of humans and chimpanzees. “Ah,” you lean closer, “now we are getting somewhere. So, exactly how similar are the brains of humans and chimpanzees? After all, if we knew *that*, couldn't we directly address the question of their mental similarity?” Well, it would be a start, anyhow. Unfortunately, comparisons of the brains of humans and apes have traditionally been limited to gross considerations such as size and surface features (such as lobes and sulcus patterns). Remarkably, the details of the internal organization of human and great ape brain systems and structures have been largely ignored, in part because it's so

---

<sup>2</sup> Jonathan Marks, *What it means to be 98% chimpanzee* (Berkeley, University of California Press, 2002).

<sup>3</sup> For examples, see: Sue Savage-Rumbaugh, *Kanzi: the ape at the brink of the human mind* (New York, John Wiley & Sons, 1994); Jane Goodall, *Through a window* (Boston, Houghton Mifflin, 1990); Roger Fouts, *Next of kin* (New York: William Morrow and Co., 1997).

<sup>4</sup> Steven M. Wise, *Rattling the cage: toward legal rights for animals*, (Cambridge, Massachusetts, Perseus Books, 2000); Paola Cavalieri and Peter Singer (Eds.), *The great ape project: equality beyond humanity*, (New York, St.Martin's Press, 1993).

---

<sup>5</sup> Enard et al. “Intra- and Interspecific Variation in Primate Gene Expression Patterns” *Science*, 296 (2002): 341-343; Todd M. Preuss, et al. “Using genomics to identify human brain specializations” *American Journal of Physical Anthropology (Supplement)*, 30 (2003): in press (abstract).

difficult to study these brains, but also because most neuroscientists have simply assumed that despite great differences in size, the internal organization of most mammalian brains is pretty much the same.

Fortunately, even this is beginning to change. For example, Todd Preuss, working at the University of Louisiana, recently made a startling discovery while comparing the brains of humans and chimpanzees. Turning his attention away from his area of previous research, the frontal lobes, Preuss decided to take a look at primary visual cortex (V1), the area of the cerebral cortex that is the first way station into processing of visual information. This is an area of the brain whose organization has been assumed to be nearly identical across primates. But there, in the middle of V1, Preuss and his colleagues uncovered a distinctively human specialization – a kind of neural architecture not found even in chimpanzees.<sup>6</sup> Preuss speculates that these changes involve modifications of the pathways related to spatial vision and motion processing. But, regardless of what this specialization is for, it suggests rethinking brain evolution in a way that's consistent with neo-Darwinian theory: similarity and difference among species as comfortable bedfellows; a state of affairs accomplished by weaving in new systems and structures alongside the old. "And if we find such differences in the middle of the primary visual cortex," Preuss recently remarked to me, "Just imagine what we're going to find when we start looking elsewhere."

Some may be surprised (or even afraid) to learn of such differences between humans and our nearest living relatives. After several decades of being fed a diet heavy on exaggerated claims of the degree of mental continuity between humans and apes, many scientists and laypersons alike now find it difficult to confront the existence of radical differences, as well. But then, in retrospect, how viable was the idea of seamless mental continuity in the first place? After all, it tended to portray chimpanzees as watered-down humans, not-quite-finished children. Despite the fact that this notion can be traced straight to Darwin, it is an evolutionarily dubious proposition, to say the least.

**I**f there are substantial differences in the mental abilities of humans and chimpanzees, in what

---

<sup>6</sup> Todd M. Preuss et al. "Distinctive compartmental organization of human primary visual cortex" *Proceedings of the National Academy of Sciences*, 96 (1999):11601-11606.

areas are they likely to exist? Over the past couple of thousand years, many potential rubicons separating human and animal thinking have been proposed. Some of these have been particularly unhelpful, such as this century's forgettable proposition by the radical behaviorists that animals don't think at all (of course, they were even skeptical about the existence of human thought, as well!). Yet, unfortunately, in the popular imagination, the question still appears to be, 'Can animals think?',<sup>7</sup> as opposed to, 'How does thinking differ across species?' (the latter being a decidedly more evolutionarily-minded question).

Assuming that chimpanzees and other species have mental states (a point I take for granted), it seems to me that a more productive question to ask is, 'What are their mental states about?' Or, put another way, 'What kinds of concepts do they have at their disposal?' It would stand to reason that the mental states of chimpanzees, first and foremost, must be concerned with the things most relevant to their natural ecology (remembering the location of fruit trees, keeping an eye out for predators, keeping track of the alpha male). And so surely chimpanzees form concepts about concrete things; things like trees, facial expressions, threat vocalizations, leopards and the like. But what about more abstract concepts? Concepts like ghosts, gravity, and God?

Admittedly, to use the term 'concept' as loosely as I have will require the indulgence of certain scholars. But perhaps some progress can be made by noting that every concept is at least somewhat 'abstract' if it extends beyond a particular example. If one has a notion of apple that is not limited to a single instance of an apple then one has made a generalization, and thus a kind of abstraction. Given that it has been known for decades or more that chimpanzees, humans, and many others species form such abstractions,<sup>8</sup> this cannot be a defining feature of human thinking.

At the risk of oversimplification, let me instead propose a distinction between concepts

---

<sup>7</sup> Eugene Linden, "Can animals think?", *Time* (March 22, 1993).

<sup>8</sup> S. L. Astley and E. A. Wasserman "Object concepts: Behavioral research with animals and young children" Pp. 440-463, In W. O'Donohue (Ed.), *Learning and behavior therapy* (Boston, Allyn and Bacon, 1997); Tom R. Zentall, "The case for a cognitive approach to animal learning and behavior" *Behavioural Processes*, 54 (2001): 65-78.

that refer to objects and events that can be directly observed (that is, things that can be detected by the unaided senses), versus hypothetical entities or processes (things that are classically ‘unobservable’). Thus, on the one hand, I wish to lump together all concepts which refer to theoretical things: all the things that are not directly registered to the senses, but are merely posited to exist on the basis of things we can observe.

Such concepts permeate our commonsense way of thinking: we explain physical events on the basis of things like ‘forces’ (supernatural or otherwise) that we have never actually witnessed, and account for the behavior of other humans on the basis of mental states we have never seen (e.g., their beliefs, desires, and emotions). They serve as the bedrock for some of our most fundamental explanations for why the world works the way it does. Furthermore we can directly contrast these sorts of concepts with ones that are derived from things that can be directly observed: apples and oranges, trees, a flash of lightning, facial expressions – even the raising of a hand or the sound of a train whistle blowing in the distance. Concepts about these things share at least one property in common: they are all derived from the world of macroscopic entities with which the primary senses directly interact. Without additional justification, I am therefore asserting a distinction between concepts that refer to observable objects and events, and ones that refer to strictly hypothetical ones.

So, here’s a proposal: the mental lives of humans and chimpanzees are *similar* in that both species form innumerable (and in many cases, identical) concepts about observable things, but, at the same time, are *radically different* in that humans form additional concepts about inherently unobservable things.<sup>9</sup>

Now, I realize that most people would not be surprised if it were established beyond doubt that chimpanzees lacked a concept of God. But what about other, seemingly more prosaic concepts that infest our way of thinking about the world? Consider the way in which we think about the social realm. In interacting with each

other (and with animals, for that matter), we use a dual system of representation: we understand other beings both as part of the observable world (they have hands and feet, and their lips form particular contortions as sounds emerge from their mouths), and as entities with mental properties – unobservable attributes like beliefs, intentions, desires, and emotions.

The proposal is that, in contrast to humans, chimpanzees rely strictly upon observable features of others to forge their social concepts. If correct, it would mean that chimpanzees do not realize that there is more to others than their movements, their facial expressions, and their habits of behavior. They would not understand that others are loci of private, internal experience. They would not appreciate that in addition to things that go on in the observable world, there are forever hidden things that go on in the private life of the mind. It would mean that chimpanzees do not reason about what others think, believe, and feel (precisely because they do not form such concepts in the first place).

Before we get too much further, let me be honest: I recognize that this proposal has troubling implications. For one thing, if chimpanzees do not reason about unobservable entities, then we would need distinctly different explanations for human and chimpanzee behavior – even in situations where the behaviors looks almost identical. Mind you, we would not need *completely* different explanations, just ones that are distinctive enough to capture the proposed difference. Nonetheless, each time we witnessed a chimpanzee engage in a complex social behavior that resembles our own, we would have to believe that, unlike us, the chimpanzee has only one conceptual system for encoding and reasoned about what is happening: a system that invokes concepts derived from observable features of the world. Thus, when chimpanzees deceive each other (which they do regularly), they would never be trying to manipulate what others believe, nor what others can or cannot see or hear, for constructs like ‘believing’, ‘seeing’, and ‘hearing’ are already deeply psychological. No, in deciding what to do, the chimpanzee would be thinking and reasoning solely about the abstracted statistical regularities that exist among certain events and the behaviors, postures, and

---

<sup>9</sup> This discussion extends several previous descriptions of this hypothesis; see, for example, my article with Jesse Bering and Steve Giambrone, “Toward a science of other minds: escaping the argument by analogy” *Cognitive Science*, 24 (2000): 509-541.

head movements (for example) of others – what we have called ‘behavioral abstractions.’<sup>10</sup>

I should note that humans, too, rely heavily upon ‘behavioral abstractions’ in their day-to-day interactions. We *must* be doing so: otherwise upon what basis could we attribute additional, psychological states to others? First, we recognize the turn of the head and the direction of the eyes (observable features), then we ascribe the internal experience of ‘seeing’ (unobservable feature). So, the proposal isn’t that chimpanzees use one system and humans use another. Rather, *both* species are purported to have access to and rely upon concepts about the observable properties of others. Instead, the proposal is that chimpanzees don’t form additional concepts about the *unobservable* properties of other beings (or the world in general, for that matter).

So, at face value, the proposal I have made is worrying. In interpreting what would appear to be the exact same behaviors in humans and chimpanzees in different ways, I seem to be applying a double-standard.

But is this implication really problematic, or does it just seem problematic because it runs counter to some of our most deeply engrained – but fundamentally flawed – ways of thinking?

**A**ssume, for a moment, that you have traveled back in time to when there were no chimpanzees on this planet – and no humans, either. Imagine further that you have come face to face with a group of animals that are members of the last common ancestor of humans and chimpanzees. Let’s stipulate that these organisms are intelligent, thinking creatures, who deftly attend to and learn about the regularities that unfold in the world around them. But let us also stipulate that they do not reason about unobservable things; they have no ideas about the ‘mind’, no notion of ‘causation.’

As you return to your time machine and speed forward, you will observe new lineages spring to life from this common ancestor. Numerous ape-like species will emerge, then disappear. As you approach the present day, you will even witness the evolutionary birth of modern orangutans, chimpanzees and gorillas. But amid all of this your attention will be drawn to one particular offshoot of this process, a

peculiar genealogy that buds off numerous descendent species. This particular lineage has evolved an eye-catching trick: it habitually stands upright; it walks bipedally. And some of its descendants build upon this trick, capitalizing upon the new opportunities it offers. For reasons that we may never fully know, tool-use and manufacture increase exponentially, language emerges, brain size triples, and, as more time passes, human material and social culture begins to accrete upon the shoulders of the lineage’s last surviving member: *Homo sapiens sapiens*. Now, imagine that as part of this process, this lineage evolved new conceptual structures (probably connected to the evolution of language) that allowed them to reason about things that cannot be observed: mental states, physical forces, spiritual deities.

I have stipulated all of this so we could confront the following question: if evolution proceeded in this quite plausible manner, then how would we expect the spontaneous, everyday behavior of humans to compare to that of chimpanzees? The answer, I think, is that things would look pretty much the way they do now. After all, humans would not have abandoned the important, ancestral psychological structures for keeping track of other individuals within their groups, nor jettisoned systems for noticing that something very different happens when Joe turns his head toward so-and-so, just depending on whether or not his hair is standing on end. No, in evolving new psychological systems for reasoning about hypothetical, internal mental states, humans would not have (indeed, could not have!) abandoned the ancient systems for reasoning about observable behavior. The new system by definition would depend upon the presence of older ones.

Now, is it really troubling to invoke a different explanation for what on the surface seem to be identical units of behavior in humans and chimpanzees? If the scenario I have outlined above is correct, then the answer must be, no. After all, for any given ability that humans and chimpanzees share in common, the two species would share a common set of psychological structures, while, at the same time, humans would augment that reasoning by relying upon a system or systems unique to our species. The residual effect of these human abilities would manifest themselves in numerous ways: some subtle (such as tightly constrained changes in the details of things to which our visual systems attends), others more profound (such as the creation of cultural artifacts like the issue of

---

<sup>10</sup> Daniel J. Povinelli and Jennifer Vonk, “Chimpanzee minds: suspiciously human?” *Trends in Cognitive Science*, 7 (2003): 157-160.

*Daedalus* in which you are now reading these words).

So much for theory. What about the empirical evidence; does it support the proposal I have just offered? Although it will not surprise you to learn that I think it does, I was not always of this opinion; I used to believe that any differences between humans and chimpanzees would have to be trivial. But the results of over two hundred studies that we have conducted during the past fifteen years have slowly changed my mind. Combined with findings from other laboratories, I have come to believe that the evidence forces us to seriously confront the possibility that chimpanzees do not reason about inherently unobservable phenomena.

Let me briefly illustrate this evidence with three simple examples: one from the social domain, one in the domain of physics, and one in the domain of numerical reasoning.

First, what does the experimental evidence suggest about whether chimpanzees reason about mental states? Although the opinions of experts differ (and have swung back and forth over the past several years), I believe that at present there is no direct evidence that chimpanzees conceive of mental states, and considerable indirect evidence that they do not. As an example, consider the well-studied question of whether chimpanzees reason about the internal, visual experiences of others (that is, whether they know anything about ‘seeing’).

To begin, no one doubts that chimpanzees respond to, reason about, and form concepts related to the movements of the head, face, and eyes of others (see Fig. 1); these are aspects of behavior that can be readily witnessed.<sup>11</sup> But what about the idea that another being ‘sees’ things; that others are loci of unobservable, visual experiences?

We have conducted dozens of studies over the past ten years to ask juvenile, adolescent, and adult chimpanzees to explore this question. Perhaps the most straight-forward of these studies involved examining how chimpanzees understand circumstances under

which others obviously can or cannot see them.<sup>12</sup> In these studies, chimpanzees were exposed to a routine in which they would approach a familiar playmate or caretaker and request a food treat using their species-typical begging gesture (see Fig. 2a). Simple enough. But on the crucial test trials, the chimpanzees were confronted with two individuals, only one of whom could see them (for example, in one condition, one caretaker had a blindfold covering her mouth, whereas the other had a blindfold covering her eyes). The question was, to whom would the chimpanzee gesture?

Not surprisingly, in our studies with human children, even two-year-olds gestured to the whoever happened to have the blindfold over her mouth (versus the eyes), probably because they represent the inner, psychological state of the other one (‘She can *see* me!’). In striking contrast, our chimpanzees did not. Indeed, in numerous examples of this kind (Fig. 2b), our chimpanzees displayed virtually no evidence that they represented the idea of ‘seeing’ as an internal experience of others.

Do not be too alarmed at this. With enough trials of any given condition the chimpanzees were able *to learn* to select whoever was able to see them. After enough trials of not being handed a banana when gesturing to someone with a bucket over her head, the chimpanzees figured out to gesture to the other person. Did this mean that they had finally discerned what we were asking them? In numerous transfer tests in which we pitted the ideas that the chimpanzees were learning simple rules based on observable cues (i.e., frontal posture, presence of the face or eyes) versus reasoning about who could ‘see’ them, the chimpanzees consistently insisted (through their behavior) that they were using rules about observable features, not internal mental states, to guide their choices.

In addition to what they learned in these tests, it also became apparent that chimpanzees come pre-prepared, as it were, to make sense of certain postures. For instance, in our tests they immediately knew what to do when confronted with someone facing them versus someone facing away. This finding (that chimpanzees are

---

<sup>11</sup> See Povinelli and Timothy J. Eddy’s “Chimpanzees: joint visual attention” *Psychological Science*, 7 (1996):129-135. (1996); S. Itakura “An exploratory study of gaze-monitoring in nonhuman primates” *Japanese Psychological Research*, 38 (1996): 174-180; Michael Tomasello, Brian Hare, and Josep Call, “Five primate species follow the visual gaze of conspecifics” *Animal Behaviour*, 58 (1998): 769-777.

---

<sup>12</sup> Our laboratory’s empirical research of chimpanzees’ understanding of ‘seeing’ has been summarized in my article, “The minds of humans and apes are different outcomes of an evolutionary experiment” Pp. 1-40, In S. Fitzpatrick & J. Bruer (Eds.), *Carving our destiny: Scientific research faces a new millennium* (Washington, DC, National Academy of Sciences and John Henry Press, 2001).

spontaneously sensitive to the communicative disparity between someone facing them versus someone facing away) has been replicated in several other laboratories.<sup>13</sup> “But if they make *that* distinction,” you wonder, “then why do they perform so differently on the other tests? Is it just because they’re confused? How are we to make sense of such a puzzling pattern of findings?”

Actually, these results are not puzzling at all if the ability to reason about mental states evolved in the manner I suggested earlier (that is, if humans wove a system for reasoning about mental states into an existing system for reasoning about behavior). After all, if the idea is correct, then chimpanzees may well be born in the world predisposed to attend to certain postures and behaviors related to ‘seeing’ (even though they know nothing at all about such mental states *per se*), precisely because overt features of behavior are the tell-tale indicators of the future behavior of others. But when such features are carefully teased apart to probe for the presence of a mentalistic construal of others, the chimpanzees stares back blankly: this is not part of their biological endowment. Thus, if the evolutionary framework I have sketched is correct, neither the chimpanzees nor the results are ‘confused’; that epithet may fall squarely upon the shoulders of we human experimenters and theorists who are blinded by our own way of understanding the world.

Of course, some have challenged this conclusion, arguing that we need to “turn up the microscope” and develop more tests that will allow chimpanzees to express their less well-developed understanding of such concepts.<sup>14</sup> So, for example, researchers at Emory University recently conducted tests in which a dominant and a subordinate chimpanzee were allowed to fight over food that was positioned in an enclosure between them.<sup>15</sup> On the critical trials, two pieces of food were present, equidistant from the

animals. The catch was that one piece of food was placed behind an opaque barrier so that only the subordinate could see it. The researchers report that when the subordinate was released into the enclosure, they tended to head for the food that was hidden from the dominant’s view, suggesting, perhaps, that the subordinate was modeling the visual experiences of his or her dominant rival.

But do such tests really help?<sup>16</sup> Do they reveal some weaker understanding of mental states in chimpanzees? Alas, these are precisely the situation in which chimpanzees will be both evolutionary primed to use their abilities to form concepts about the behavior of others to guide their social behavior. So, for example, they can simply know to avoid food out in the open when a dominant animal is about to be released. “But still,” the skeptic within you asks, “that’s pretty smart, isn’t it? The chimpanzees would have to be paying attention to who’s behind the door, and what that other individual is going to do when the door opens, right?”

Fair enough. But that, in the end, is the point: chimpanzees can be intelligent, thinking creatures even if they do not possess a system for reasoning about psychological states like ‘seeing.’ If it turns out that this is a uniquely human system, it will take nothing away from the evolved intelligence of apes. By way of analogy, the fact that bats echolocate but humans don’t, hardly constitutes a crisis for evolutionary theory.

In the final analysis, the best theory will be the one that explains both data sets: the fact that chimpanzees reason about all the observable features of others that are associated with ‘seeing,’ but at the same time exhibit a striking lack of knowledge when those features are juxtaposed in a manner they have never witnessed before (i.e., blindfolds over eyes versus over the mouth). I submit that, for the time being, the evolutionary hypothesis I have described best meets this criterion.

---

<sup>13</sup> For example see A. B. Hostetter et al. “Differential use of vocal and gestural communication by chimpanzees (*Pan troglodytes*) in response to the attentional status of a human (*Homo sapiens*)” *Journal of Comparative Psychology*, 115 (2001) 337-343.

<sup>14</sup> Tomasello et al., “Chimpanzees understand psychological states – the question is which ones and to what extent” *Trends in Cognitive Science*, 7 (2003): 153-156. p. 156.

<sup>15</sup> Brian Hare et al. “Chimpanzees know what conspecifics do and do not see” *Animal Behaviour*, 59 (2000): 771-785; But see M. Rosalyn Karin-D’Arcy and Povinelli, “Do chimpanzees know what each other see? A closer look” *International Journal of Comparative Psychology*, 15 (2002): 21-54.

---

<sup>16</sup> A recent and thorough analysis of the diagnostic potential of these (and other tests) is provided by Povinelli and Vonk, who argue that the logic of current tests with chimpanzees (and other animals) cannot, in principle, provide evidence that uniquely supports the notion they are reasoning about mental states (as opposed to behavior alone), and they therefore advocate a new paradigm of tests which may have such diagnostic power. An alternative point of view is provided in the companion piece by Tomasello et al. However, I believe that this alternative view dramatically underestimates the representational power of a psychological system which forms concepts solely about the observable aspects of behavior.

A second example of the operation of what may be a uniquely human capacity to reason about unobservables comes from comparisons of human and chimpanzees' commonsense understanding of physics. Humans – even very young children – seem disposed to assume that there's more to the physical world than what meets the eye. For example, when one ball collides with another, stationary one, and the second speeds away, even quite young children are insistent that the first one caused the second to move away. Indeed, as Michotte's classic experiments revealed, this seems to be an automatic process in adult humans.<sup>17</sup> But what is it, exactly, that humans believe *causes* the movement of the second ball? As Hume noted long ago, it is not merely the fact that the objects touched; that's just a re-description of the observed events.<sup>18</sup> No, the first one is seen as having transmitted something to the second object, some kind of 'force.' But where is this force? Can it be seen? No, it is a theoretical thing.

In an initial five-year study of 'chimpanzee physics', we focussed our apes' attention on simple tool-using problems.<sup>19</sup> Given their natural expertise with tools, our goal was to teach them how to solve simple problems (tasks involving pulling, pushing, poking, etc.), and then use carefully-designed transfer tests to assess their understanding of why the tool objects produced the effects they did. In this way, we attempted to determine if they reason about things like gravity, transfer of force, mass, physical connection, or merely form concepts about spatio-temporal regularities. To do so, we contrasted such concepts with their perceptual 'ambassadors' (see Table 1), much in the same way we had contrasted the unobservable psychological state of 'seeing' with the observable behavioral regularities that co-vary with 'seeing'.

*Table 1*  
Theoretical causal constructs and their observable 'ambassadors'

Theoretical	Paired observable
-------------	-------------------

concept	'ambassador'
gravity	downward object trajectories
transfer of force	motion-contact-motion sequences
strength	propensity for deformation
shape	perceptual form
physical connection	degree of contact
mass	muscle/tendon stretch sensations

To pick just one example, we explored in detail the chimpanzee's understanding of physical connection (the idea that two objects are bound together through some unobservable interaction such as the force transmitted by the mass of one object resting on another, or the frictional forces of one object against another; or conversely, the idea that simply because two objects are physically touching does not mean there is any real form of 'connection'). We presented our chimpanzees with numerous problems, but consider the one illustrated in Figure 3a. Here, the chimpanzees were first taught to use a simple tool to hook a ring in order to drag a platform with a food treat on it towards them. Although they all learned to do so, our real question was whether, when confronted with a new situation (Fig. 3b), they would invoke the notion of physical connection and select the 'correct' option. Consistent with our findings using other tests, they did not. Instead, 'perceptual contact' seemed to be their operating concept. The observable property of 'contact' (of any type) was generally sufficient for them to think that a tool could move another object.

Finally, consider the chimpanzee's numerical understanding. Over the past decade or so, it has become apparent that many species share what Stanislas Dehaene has called a 'number sense' – an ability to distinguish between larger and smaller quantities, even when the volume occupied by the objects is equated.<sup>20</sup>

<sup>17</sup> A. Michotte, *The perception of causality* (New York, Basic Books, 1963).

<sup>18</sup> David Hume, *Treatise of Human Nature*, (Vols. 1-2) Ed. by A.D. Lindsay, (London, Dent, 1739/1911).

<sup>19</sup> Daniel J. Povinelli, *Folk physics for apes*, (Oxford, Oxford University Press, 2000)

<sup>20</sup> Stanislas Dehaene, *The number sense*, (Oxford, Oxford University Press, 1997).



In an attempt to explore the question of ‘numerical reasoning’ in animals, several research laboratories have trained apes to match a specific quantity of items (say, three jelly beans), with the appropriate Arabic numeral (‘3’).<sup>21</sup> That they can accomplish this should not be the least bit surprising: humans and chimpanzees (and many other species) share the ability to visually individuate objects. However, after years of training, the most apt of these pupils have gone on to exhibit some understanding of *ordinality* (the idea that the value of the numeral ‘5’ is larger than the value of ‘4’, for example). So, isn’t this evidence that chimpanzees have a solid grasp of the notion of number?

Let us scratch the surface a bit, looking at these findings from the perspective I have been advocating. First, do these chimpanzees possess a dual understanding of their numbers, both as associates of real object sets *and* as inherently theoretical things, such that every successive number in the system is exactly 1 more than the previous number? The training data from even the most mathematically-educated of all chimpanzees, Ai, suggests that they do not. For example, each time the next numeral was added into her training set, it took her just as long to learn its association with the appropriate number of objects as the previous numeral. In other words, there appeared to be little evidence that Ai understood the symbols as anything other than associates of the object sets. Furthermore, even her dedicated mentors suggest that Ai was not ‘counting’ at all. With small quantities (up to 3 or 4 objects), she performed like humans, using an automatic process (‘subitizing’) to make her judgements. But with larger quantities, she exhibited striking differences from humans. Instead of counting, it appears as if she was simply estimating ‘larger’ or ‘smaller.’

What about ordinality? When first tested for her understanding of the relative ordering of her numbers, Ai exhibited no evidence that this was part of her conceptual structure (that is, when presented with pairs of numbers, 1 versus 8, for example, she did not

seem to have any notion that the value of ‘1’ is ‘smaller’ than the value of ‘8’ – despite the fact that she had been correctly matching these numerals to object sets for years!) Of course, after extended training, Ai did eventually exhibit evidence for this ability, and now, after over 15 years of training, when confronted with a scrambled array of the numerals 1-9, she has the remarkable ability select them in ascending order.

But what does it mean that under the right training regime, we can guide a chimpanzee like Ai into a performance that looks in many (but not all) respects, like human counting? One interpretation is that a basic ‘number sense’ – a system grounded to individual macroscopic objects – is widespread among animals, and that apes (and other animals) can use this ability (in concert with their other cognitive skills) to figure out ways to cope with the ‘rules’ that humans establish in their tests. In contrast, the human system for counting (as well as other mathematical ideas) could be seen as building upon these older systems by reifying numbers as things in their own right – theoretical things. This may seem like a subtle and unimportant distinction for some tasks, but it may be one which leaves the ape mystified when it faces questions that treat numbers as things in their own right (questions that pick out ‘number’ as a theoretical thing).

As a striking example of the distinction I have been trying to draw, consider ‘0,’ surely one of the purest examples that exists of an inherently unobservable entity. If I am right, then ‘0’ ought to be virtually ‘undetectable’ by the chimpanzee’s cognitive system. And indeed, the data seem to bear this out.<sup>22</sup> For all her training, even Ai does not appear to have learned to understand ‘0’ in this sense. True, she (and other animals) have quickly learned to pick the numeral ‘0’ in response to the absence of any objects (something easily explained by associative learning processes). But tests of ordinality involving zero (choosing whether ‘0’ is greater or lesser than ‘6’, for example) have consistently revealed what I believe might be best described as the virtual absence of the concept. Although this training has gradually forced her ‘understanding’ of ‘0’ into a position further and further down the ‘number line,’ even

---

<sup>21</sup> For this discussion, I rely heavily on the detailed results from Ai, a 25-year-old chimpanzee whose numerical abilities have been studied since she was 5 by a team led by Tetsuro Matsuzawa in Kyoto, Japan. See Dora Biro and Tetsuro Matsuzawa “Chimpanzee numerical competence: cardinal and ordinal skills” Pp. 199-225, In T. Matsuzawa (Ed.) *Primate origins of human cognition and behavior* (Tokyo, Springer, 2001).

---

<sup>22</sup> Dora Biro and Tetsuro Matsuzawa. “Use of numerical symbols by the chimpanzee (*Pan troglodytes*): cardinal, ordinals, and the introduction of zero” *Animal Cognition*, 4 (2001): 193-199.

to this day, after thousands of trials, Ai still reliably confuses '0' with '1' (and in some tasks, '2' and '3', as well). However one wishes to interpret such findings, it is certainly not consistent with a understanding of the very essence of zero-ness.<sup>23</sup>

**O**ur work together is done. To the best of my ability I have laid out the case for believing that chimpanzees can be bright, alert, intelligent, fully 'cognitive' creatures, and yet still have a mind of their own. From this perspective, it may be our species that is the peculiar one; creatures unsatisfied in merely knowing *what* things happen, but continually driven to explain *why* they happen, as well. Armed with a communicative system (natural language) that makes referring to abstract things easy, we continually pry behind appearances, probing ever deeper into the causal structure of things.

And yet I cannot help but suspect that many of you will react to what I have said with a feeling of dismay – perhaps loss; a sense that if the possibility I have sketched here turns out to be correct, then our world will be an even lonelier place than it was before. But for the time being, at least, I ask you to stay this thought. After all, would it really be so disappointing if our first, uncontaminated glimpse into the mind of another species revealed a world strikingly different from our own, or all that surprising if the price of admission into that world were that we check some of our most familiar ways of thinking at the door? No, to me, the idea that there may be profound psychological differences between humans and chimpanzees no longer seems unsettling. On the contrary, it's the sort of possibility that has, on at least some occasions, emboldened our species to reach out to new worlds with open minds and hearts.

---

<sup>23</sup> One might retort that the symbol for '0' appeared quite late in human history. But here's a thought experiment. Dust off your time machine, travel back to those civilizations that predate the invention of the numeral '0'; I am willing to bet that you would make short shrift of the task of teaching those adult humans the position occupied by the symbol for zero.



Figure 1. Gaze-following in a 5-year-old chimpanzee.

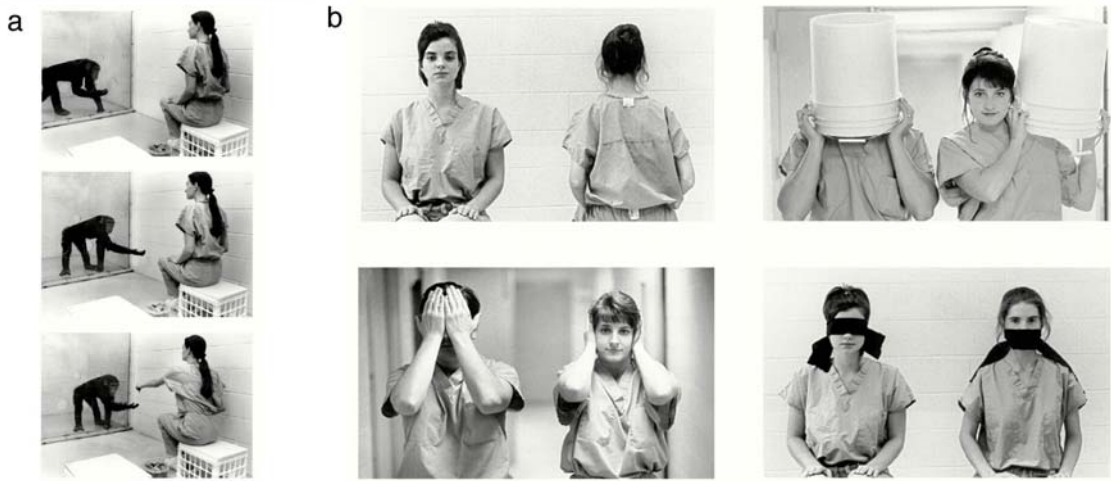

Figure 2. (a) Adolescent chimpanzee uses her species-typical gesture to request food from a familiar caretaker. (b) Various conditions used to instantiate 'seeing' versus 'not seeing.'

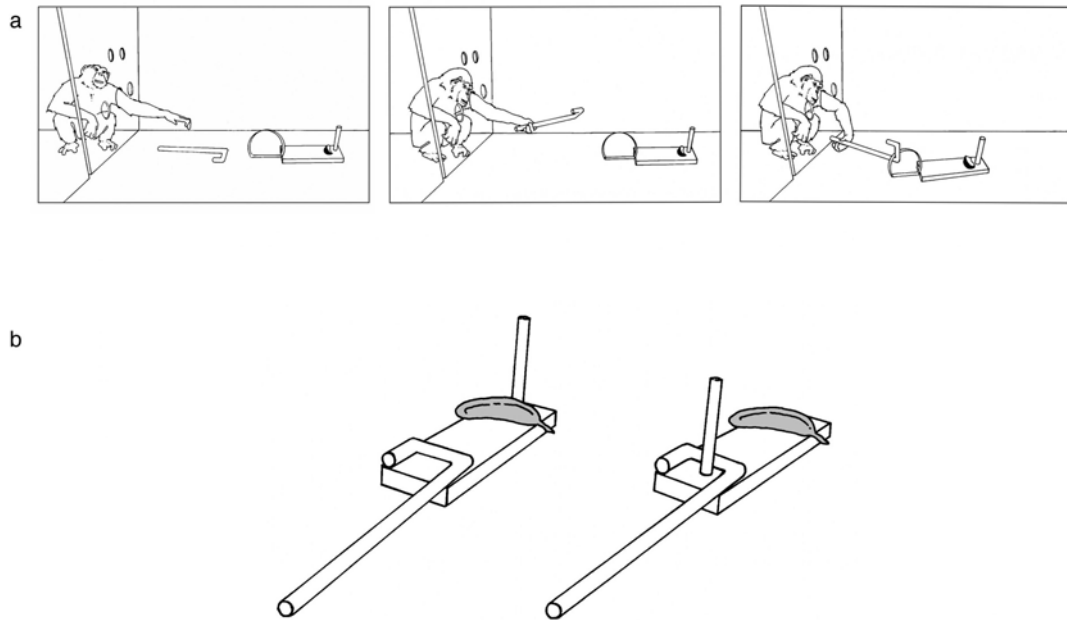

Figure 3. (a) Initial training task. (b) Transfer test to assess the chimpanzee's understanding of 'physical connection.'